

Top View of fabric parts.

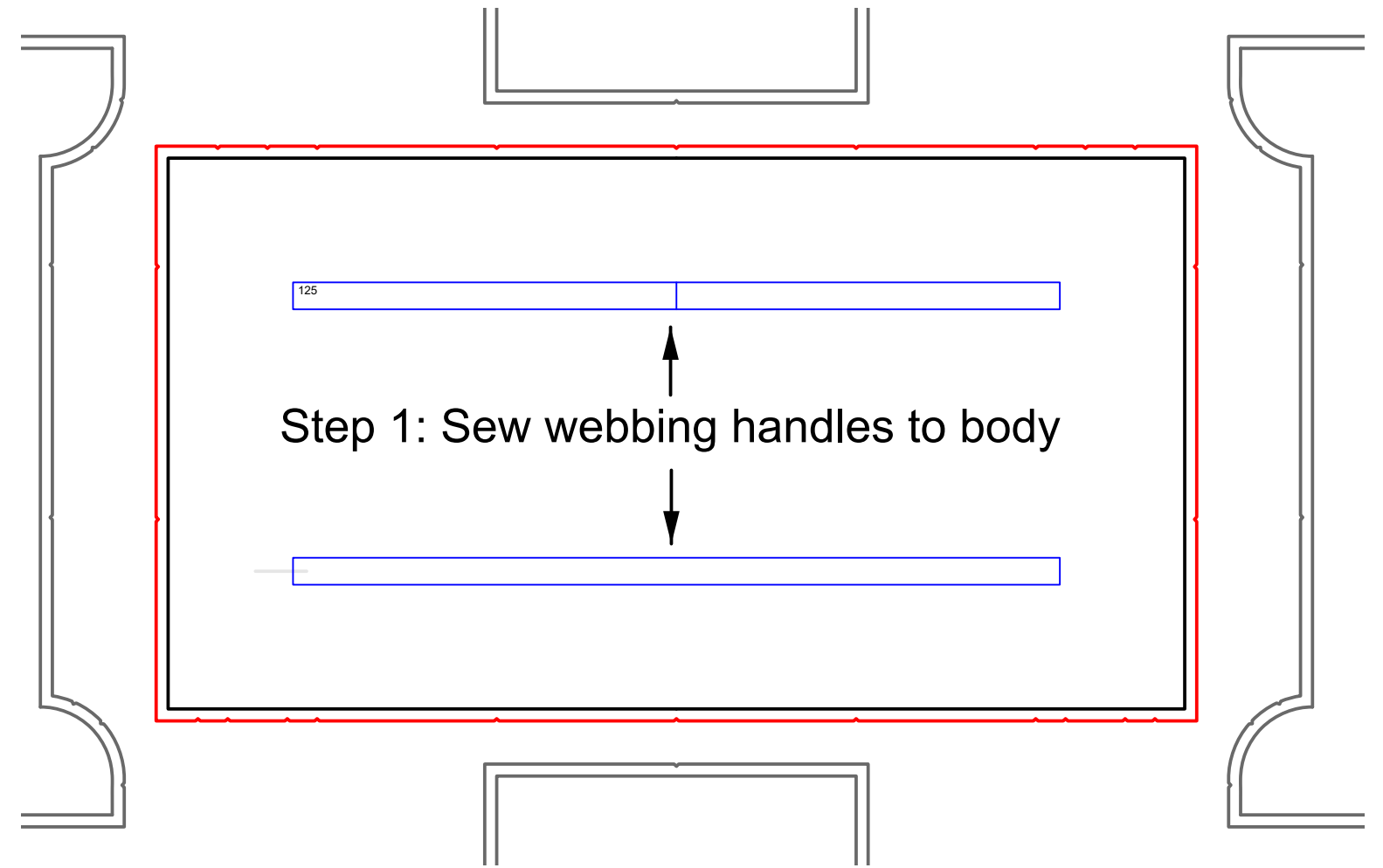

Step 2: Sew in #15 zipper and add slider.

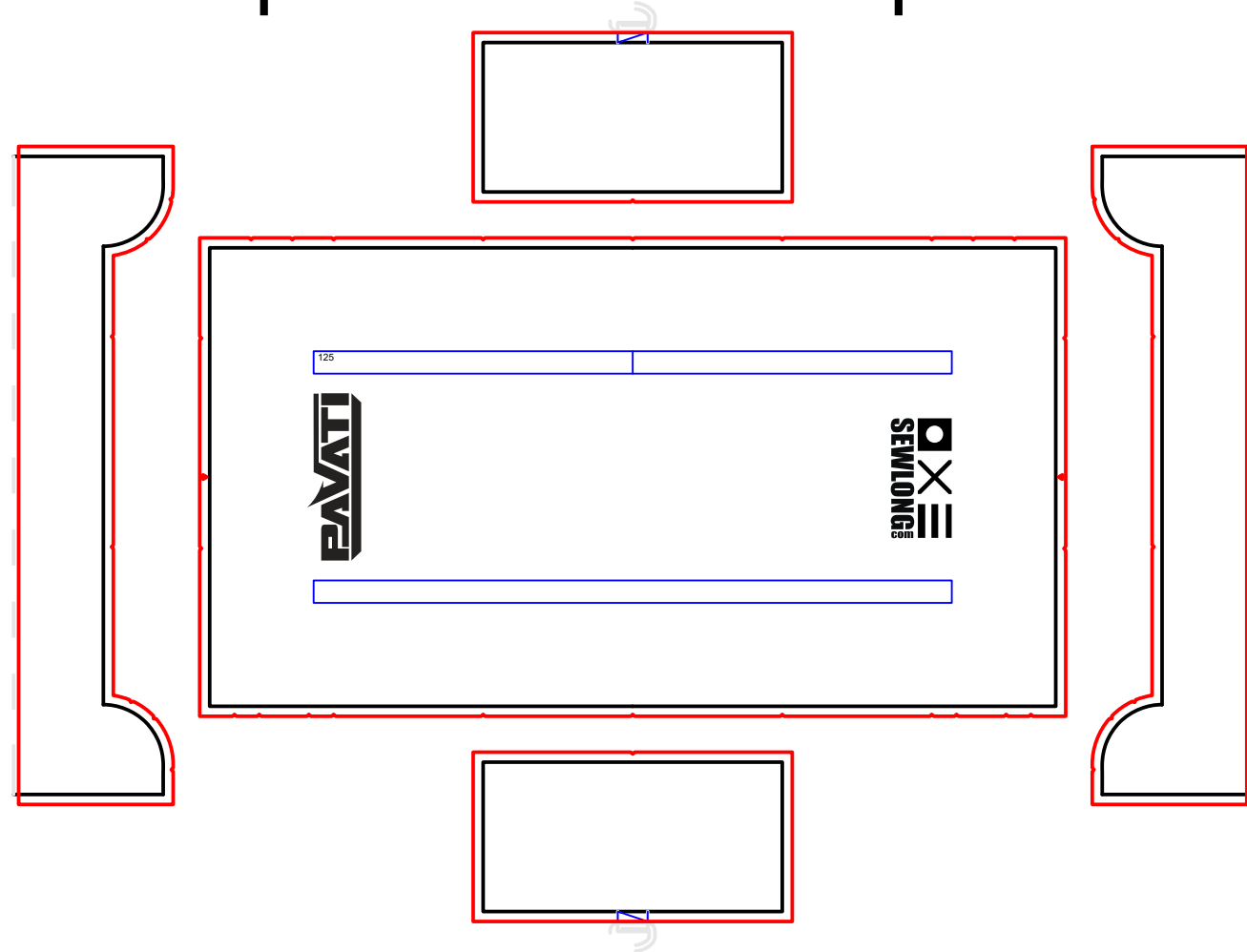
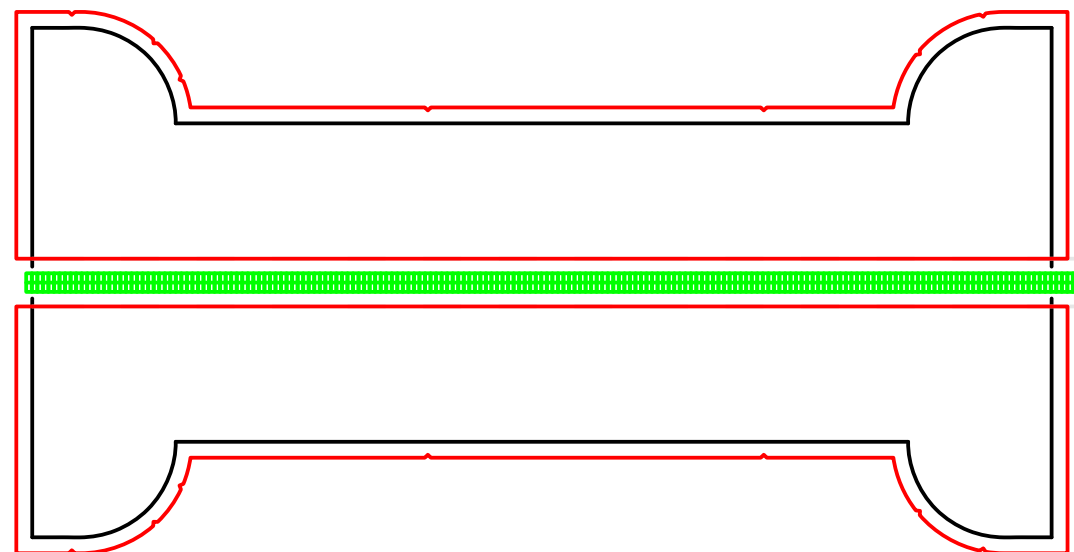

#15 Zipper

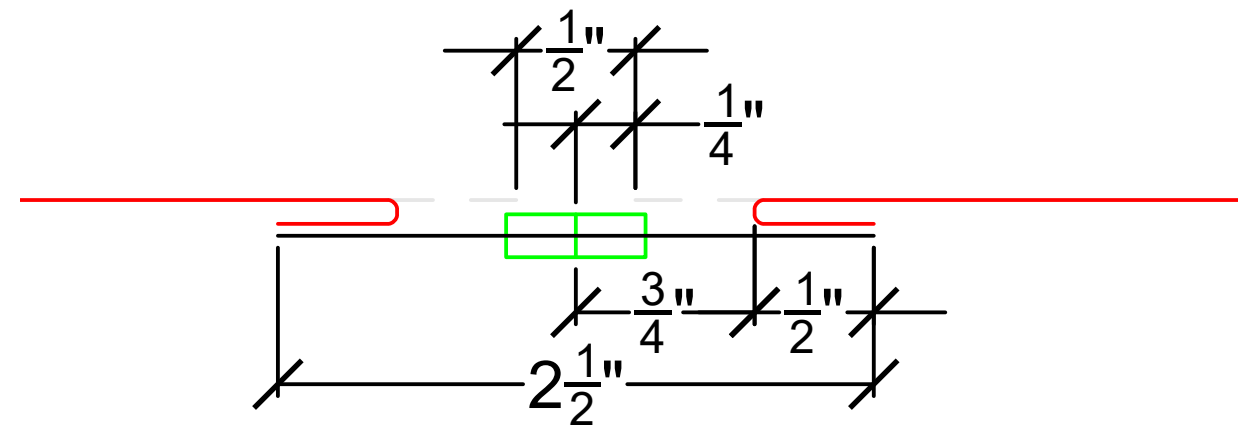

	Project No: 1885	Title: Sew 1	Plot View: Finish Side
	Drawn By: Clint	Description: Cinch Cover Zip Top Bag	
	Units: inches	Number of Drawings: 1 of 3	Customer Name:
	Date Modified: ####	Materials: Balistic Nylon, #15 zip	

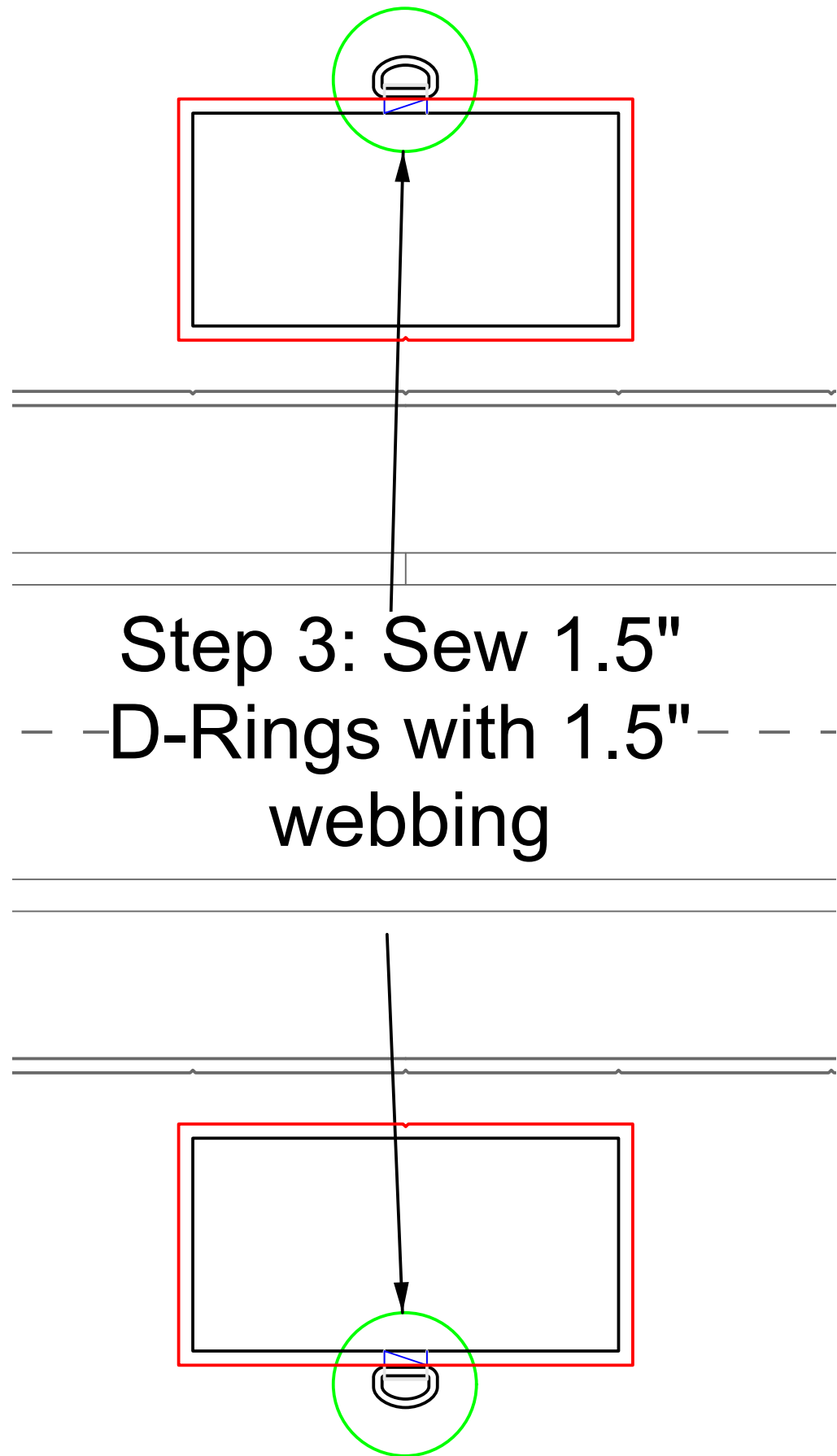

Step 3: Sew 1.5"
D-Rings with 1.5"
webbing

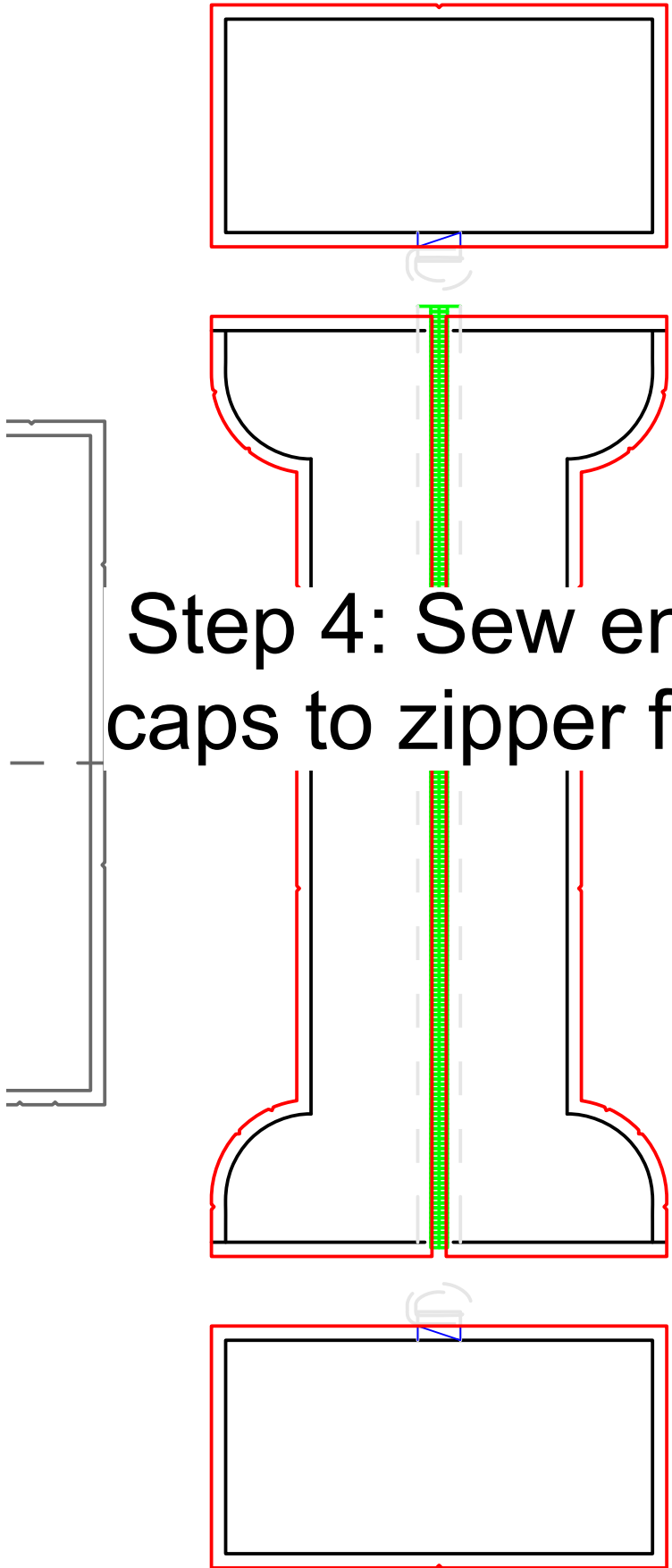

Step 4: Sew end
caps to zipper flap

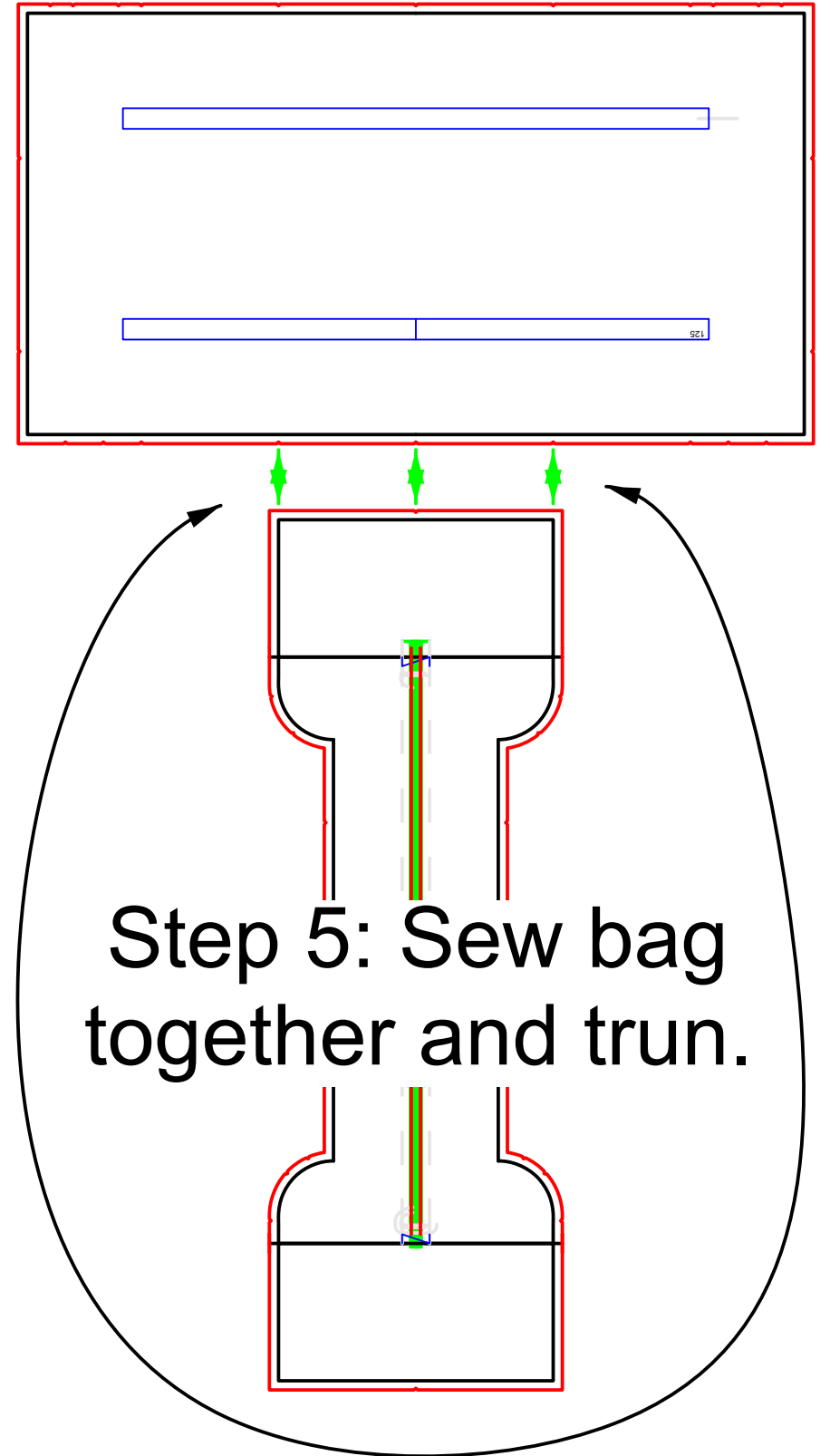

Step 5: Sew bag
together and trun.

	Project No: 1885	Title: Sew 2	Plot View: Finish Side
	Drawn By: Clint	Description: Cinch Cover Zip Top Bag	
	Units: inches	Number of Drawings: 2 of 3	Customer Name:
	Date Modified: ####	Materials: Balistic Nylon, #15 zip	